

SWISS TYPE AUTOMATIC LATHE equipped with star motion control system 

# SR-38 type B

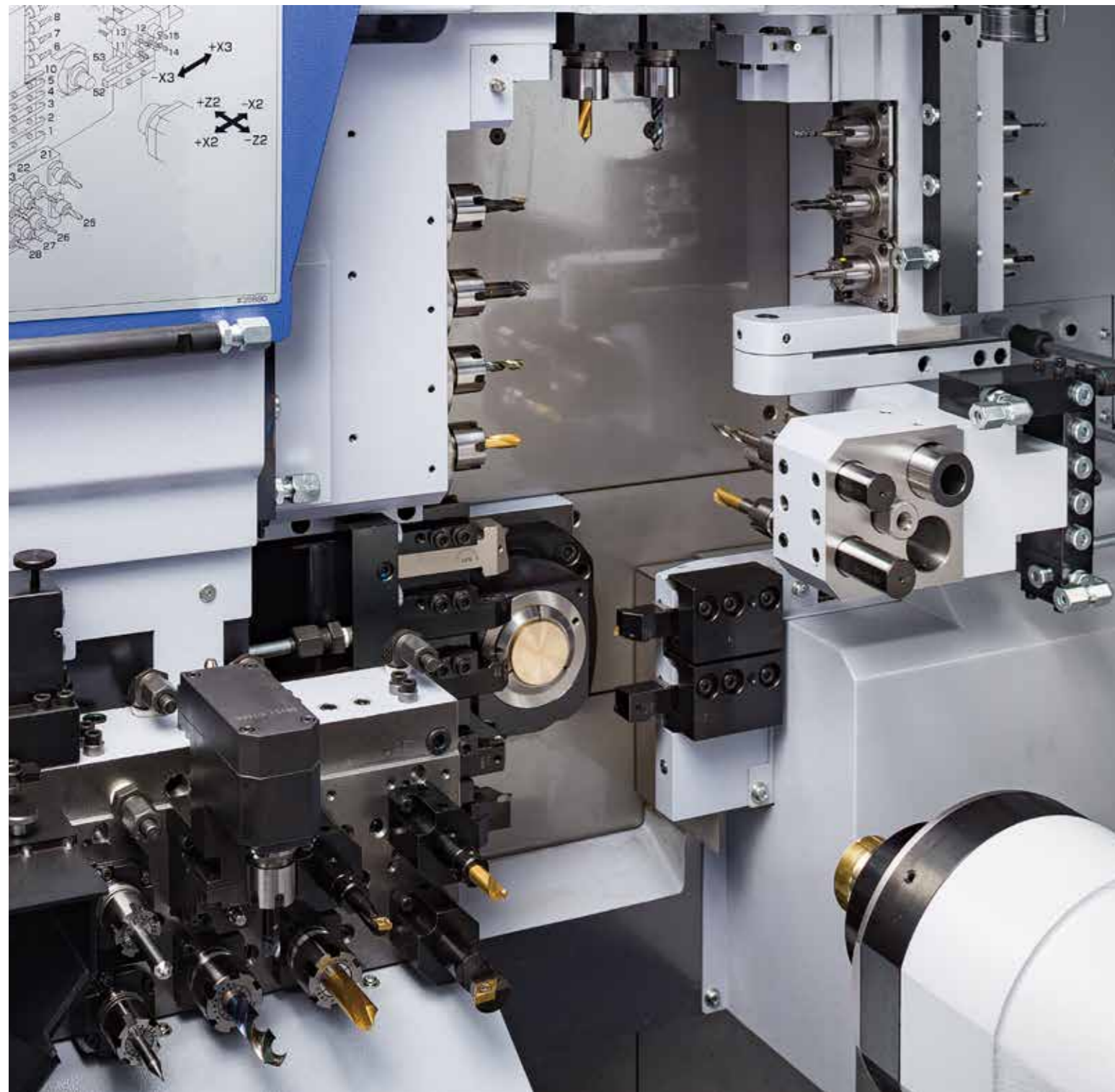

The machine configuration is designed to further assist the production of medium complex components in the large-diameter sectors.



**This Quick and versatile multi axis machine offers many functions like balance turning, a fully programmable B axis together with an independent 8-spindle backworking unit for maximum overlapping capability.**

This modern machine is designed for large-diameter workpiece production and further enhances the SR series of machines. The rigid platen type tool post incorporates a "uniform load cross guide structure" which minimizes momentary load applied to the LM guide bearings and therefore improves tool post rigidity. The balance turning function is made by means of the simultaneously controlled X1/X3 axes, the 3 spindle Counterface B axis unit enables angular drilling on both main & sub spindles and the Y axis-controlled 8-spindle backworking unit, further enhances the degree of complexity of part that can be produced on this machine. The cartridge type power tool positions provide the flexibility to mount many different driven tools like Thread whirling, polygon milling and slotting units

For customers wishing to produce even more complex components with high accuracy and high production requirements the SR-38B makes this possible.

## SR-38 type B

CNC SWISS TYPE AUTOMATIC LATHE equipped with Star motion control system

Control method : CNC control by Star motion control system

Machine composition :

- Main spindle
- Sub spindle
- Gantry-type tool post (B-axis control power-driven tool unit)
- 8-spindle back working unit with Y-axis control function

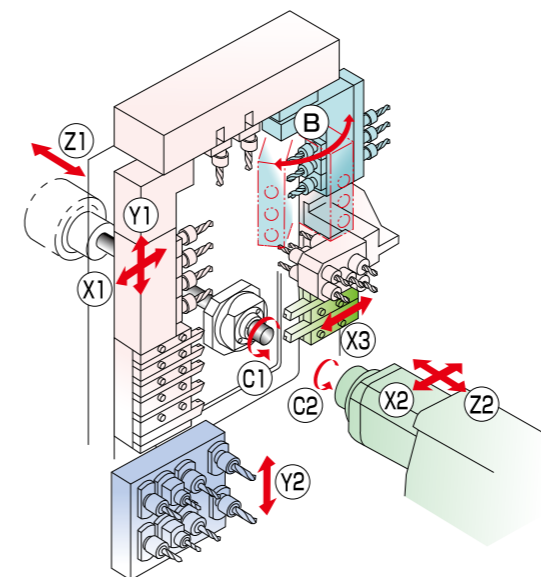

### TOOLING SYSTEM

■ Tool holder	Turning tool	7 tools (5 tools on the front / 2 tools on the rear)
■ 5-spindle sleeve holder	Front-end stationary tool	5 tools
	Rear-end stationary tool	5 tools
■ Power-driven tool	Cross machining tool only	4 tools
	Cartridge type	2Pos
	Power-driven tool unit	1 Pos (front 3 tools / rear 3 tools)
■ Back 8-spindle unit	Rear-end stationary tool	Max. 8 tools
	Rear-end power-driven tool	Max. 8 tools



# In pursuit of up-graded function, production and accuracy from every angle

## High Functionality & Enhanced Machining Capability

### ① X3 controlled axis added

A tool holder with X3-axis control function is provided on the rear side of the platen-type tool post.

### ② Angle adjustable power tool unit

Equipped with programmable 3-spindle counter facing-type unit with a B-axis. Capable of oblique machining such as oblique holes on both front and back sides.

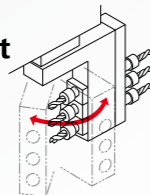

### ③ Two cartridge positions

Various power tool units can be mounted at the cartridge positions for slitting, polygon processing, etc. to realize a variety of tooling layouts suited to workpieces to machine.

### ④ G. B & N.G.B change-over mechanism

The guide bush type and the non-guide bush type can be changed over according to the total length of workpieces to achieve optimum machining.

The display shows every step to follow through a blinking lamp to support a smooth change-over operation.

By proceeding with the job in accordance with the procedures displayed on the operation panel, switching from the guide bush type to non-guide bush type is easily accomplished.



## Striving for High Productivity (& Reduced Machining Time)

### ① Balance cut mechanism

Balance cutting using the X1/X3 simultaneous control reduces the machining time especially in hard to machine materials.

### ② Flexible overlap machining

The 8-spindle backworking unit with Y-axis control ensures efficient process splitting between front and back workings and flexible overlap machining.

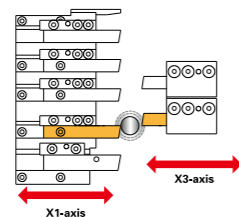

### ③ Star motion control system

Type B is equipped with unique Star motion control system to minimize the control system change-over time, tool change time and other non-cutting time. Improved productivity is emphasized from the view point of both the mechanical and control sides.

Significant Reduction of Non-Cutting Time

## Star Motion Control System

This control system converts the NC program through "optimization" and finishes processing related to switching of the control system in order to enable "tool selection for the next process and approach during cutting" and "tool disengagement and next cutting at the same time".

By this control method, the non-cutting time, which is considered to be a disadvantage for NC-controlled machines, is largely reduced and contributes to improved productivity. - Furthermore, this control system moves each axis while taking the shortest way, utilizing the previous cutting process time to minimize excessive vibration caused by axis feed and contributes to the maintenance of stable machining accuracy.

### ① Concept of cutting time reduction

#### Conventional CNC-controlled machining

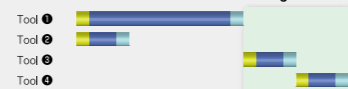

#### Machining through Star motion control system



By the program optimization, the time required for the processes of [Disengagement], [Next tool selection] and [Approach] can be minimized to reduce the non-cutting time.

## High Rigidity & High Accuracy Achieved

### ① Platen type tool post employing uniform load cross guide structure

The platen type tool post incorporates a tool post with 8 linear bearings arranged uniformly around the point (= guide bush) where a cutting load is applied. By distributing the cutting load to 8 guide bearings at all times, the moment load applied to each guide bearing is minimized and rigidity of the tool post is improved.

Thanks to high dynamic stability, continuous operation is possible for a long time with stable accuracy and longer service life of the linear guide bearing is ensured.

#### X,Y AXIS POSITION ①

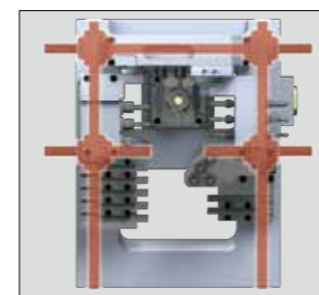

#### X,Y AXIS POSITION ②

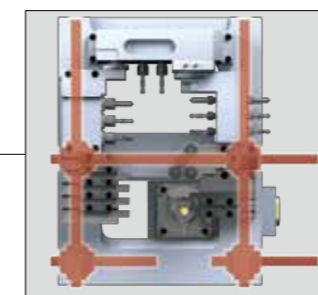

#### X,Y AXIS POSITION ③

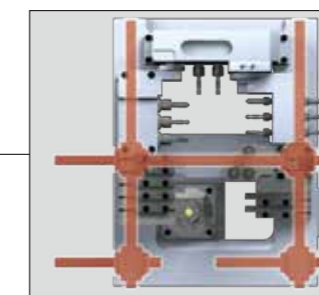

Uniform Load Cross Guide Structure

High rigidity tool post

The moment load is applied to eight bearings uniformly at all times even when the XY axis moves because the guide bush is positioned in the guide bearing. (See figures ①, ② and ③)

### ② Spindle sleeve slide guideway structure (N.G.B type)

The machine is so constructed to guide the Z axis along the spindle sleeve outer periphery of the headstock. Machining load is supported close to the cutting point so that the headstock rigidity is improved and continuous machining with stable accuracy is ensured.

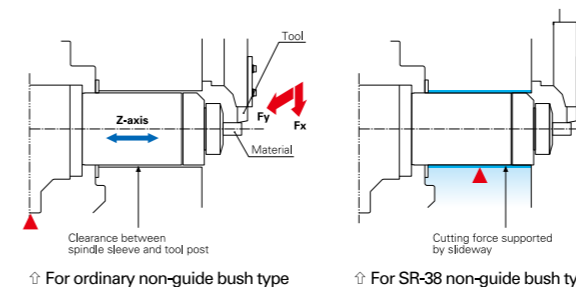

### ③ Introduction of built-in spindle

Introduction of the built-in type spindle and sub spindle enhances indexing accuracy.

### ④ Hydraulic spindle chucking unit

The spindle chucking unit uses a hydraulic rotation cylinder to achieve stable chucking capability regardless of variations in diameter of large-diameter workpieces.

### ⑤ Higher rigidity of each section

The machine is carefully designed for higher rigidity by employing a slide guideway of the rear side X3 tool post, both end support structure of swivel type 3-spindle unit, etc.

## Improved Operability and Productivity

### ① Movable operation panel

The movable operation panel allows operation at the best position for operation.

### ② Swing-up door

The swing-up door allows enlarged opening of the headstock chamber and the cutting chamber, and ensured a large work space.

STAR Environmental Standards Conformity models



Star Micronics defines machine tools conforming to the following environmental standards as "Star Environmentally Compatible Machines".

Adaptation Criterion  
 ● Powder-coated external cover  
 ● RoHS compliance part ratio: 99% or more

# A Variety of Tooling Layouts



## TOOLING SYSTEM Gantry-Type Tool Post

### Basic type

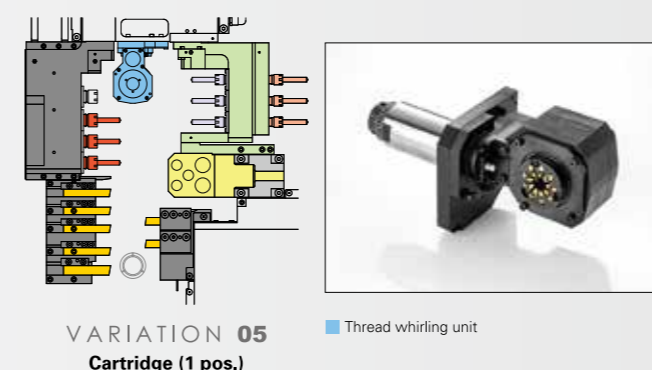
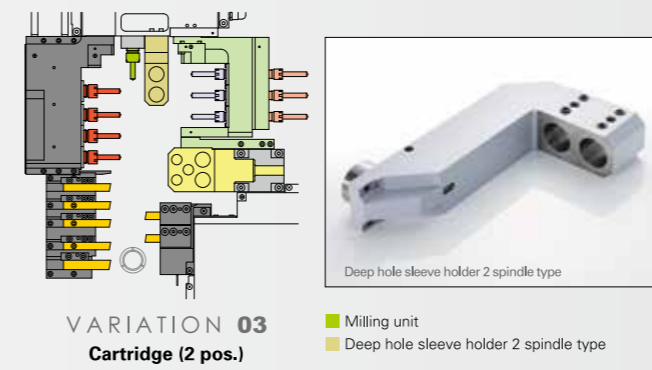
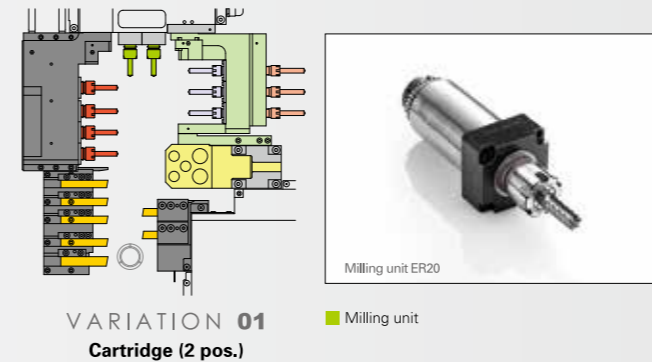
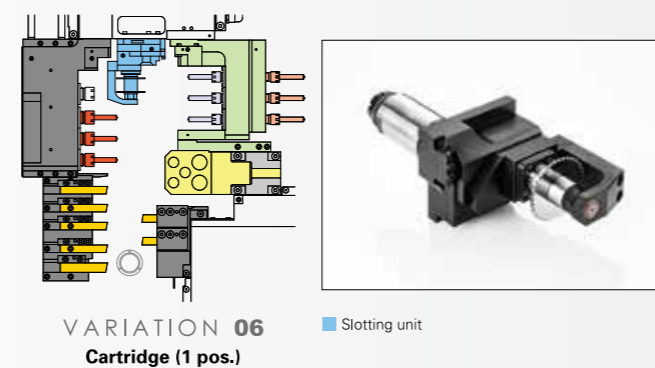
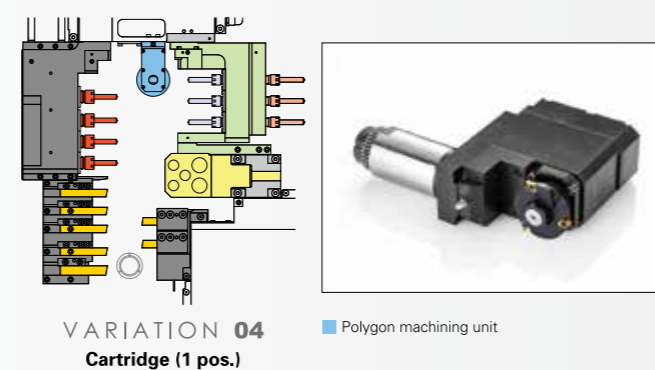
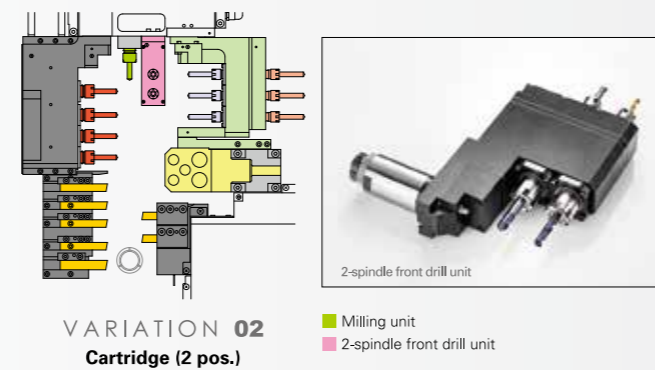
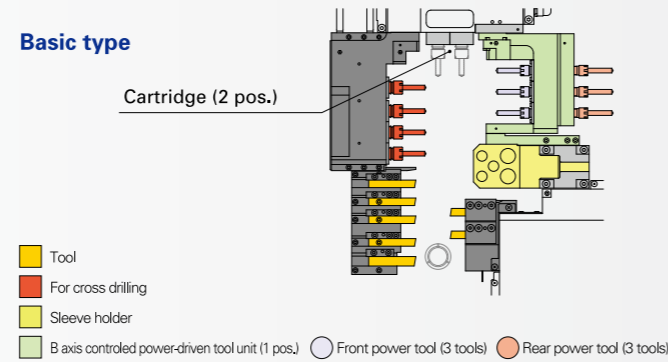

## TOOLING SYSTEM 8-spindle back working unit with Y-axis control function

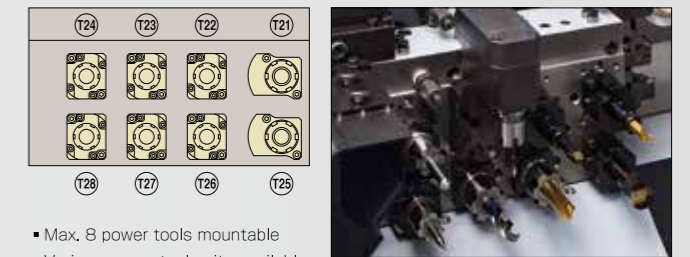

- Max. 8 power tools mountable
- Various power tool units available
- Compliant with coolant-through tools

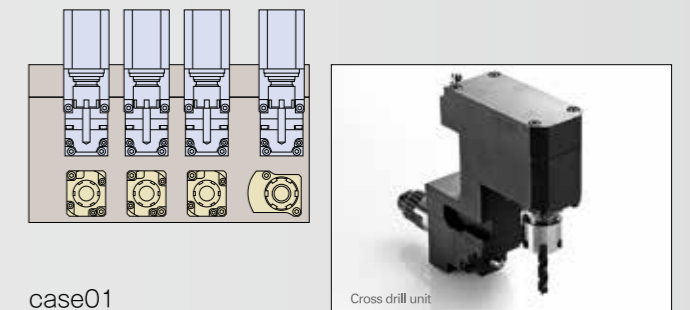

- case01**  
Mounting of cross drill unit
- Mounting at T21 through 24 positions
  - Continuous mounting at adjoining positions

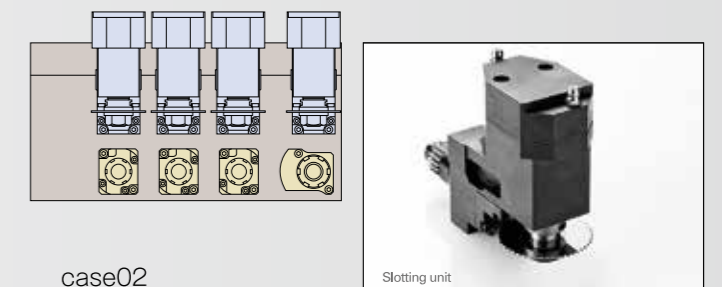

- case02**  
Mounting of slotting unit
- Mounting at T21 through 24 positions
  - Continuous mounting at adjoining positions



A tool setting station designed for advancement of multi-processing. Not only milling and face drilling but also thread whirling, slotting, polygon processing units as well as deep-hole drill sleeve and other tool units are included in the line of products. The optimum layout can be selected from the wide array of tooling systems to meet user needs and expand possibilities for machining variations.



# A wide range of machining variations

## Front working variation

VARIATION 01

**Balance cutting**  
X3 axis controlled balance cut

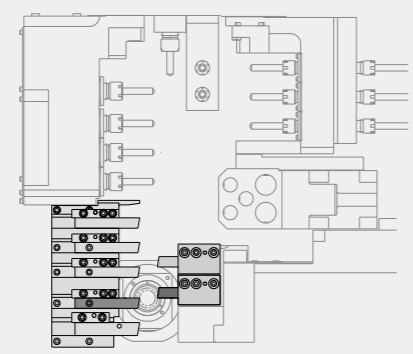

VARIATION 02

**B axis swing**  
B axis power tool swivel control

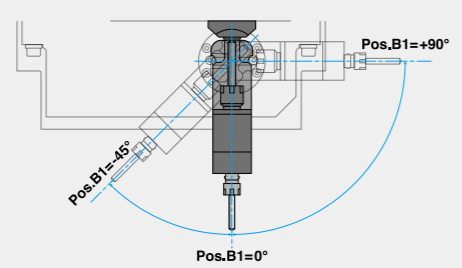

VARIATION 03

**Diagonal machining**  
Diagonal machining using power-driven tool with B axis/angle adjustable power-driven tool

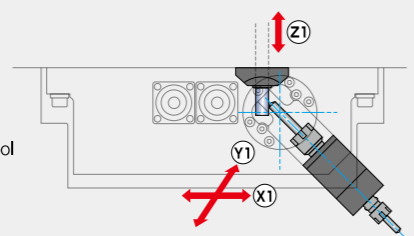

## Rear working variation

VARIATION 01

**Cross drilling**  
Back cross drilling

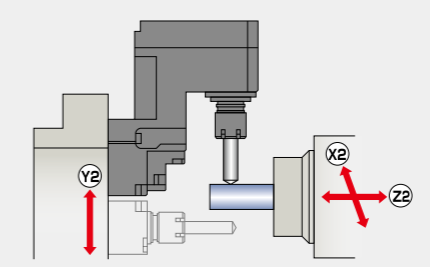

VARIATION 02

**Diagonal machining**  
Back diagonal machining using power-driven tool with B axis/angle adjustable power-driven tool

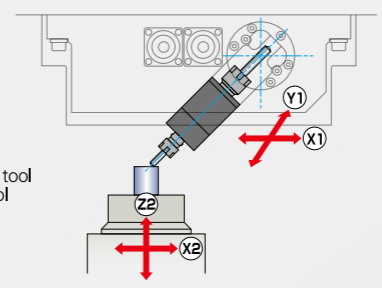

# The NC System Continues to Evolve to be Friendly to Every Operator.

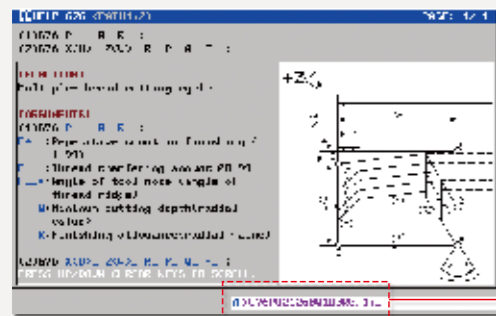

## Convenient command help screen !

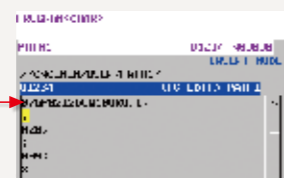

An image is displayed on the command help screen to check detailed command so that the help contents can be understood by intuition. Code inputting to insert into the currently edited program is also possible with the help screen displayed.

## Convenient Alarm Help Function



The Star original alarm help screen is added. When [Help] is selected from the bookmark, the pop-up screen is displayed and alarm details can be checked even if there is no instruction manual. Together with the troubleshooting information, a list of personnel who can remove the alarm is also displayed to clear the problem smoothly.

## Convenient count-up prediction function !

Tool life can be managed for each tool number. The count arrival forecast function also gives warning through the count arrival forecast time display, tool counter red display and operator message (No. 2047) display if any tool life is expected to expire within 24 hours. With this function, the operator can prepare a replacement tool before the machine stops and reduce the non-running time.

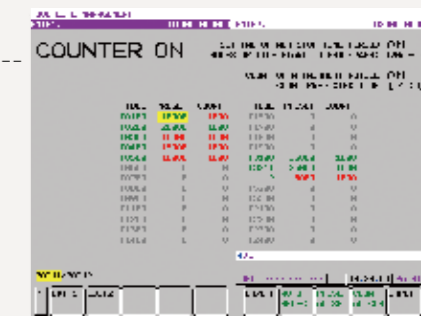

## Convenient tool selection function !

A tool selected on the screen can be positioned with the machining chamber door opened. Simultaneous operation, using two buttons, is also possible. In order to emphasize safety during operation. Positioning not only in the axial (X) direction but also center height (Y) direction is also possible.

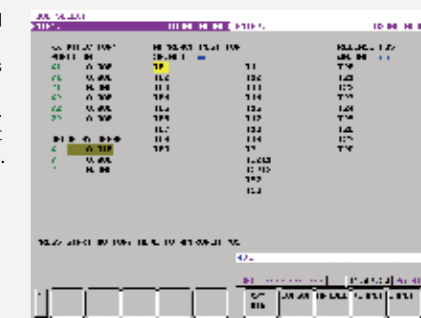
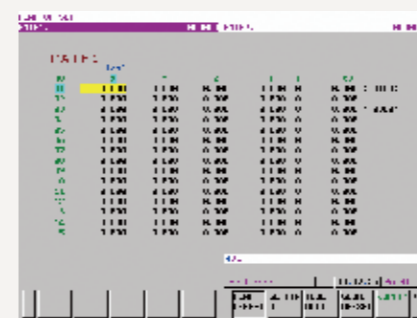

## Convenient Wear Offset Screen

The tool wear offset number which is used is displayed on the right end of the screen during execution of the machining program. This enables to check the applicable offset number easily when changing the offset value.

## Multi-System Program Control

Program input/output between the NC unit and the memory card can be done by a single operation for all systems. Programs for all systems can be compiled in one file (with extension ".AP"). Copy, delete and new creation can also be done by one operation.

\*Files with an extension ".PA" are supported by Star program control software "PU-Jr." Non-compliant models will gradually be changed to be compliant in the future.

MULTI-PATH	USED PAGE	MEMORY CARD
00000	00000	00000
00001	00001	00001
00002	00002	00002
00003	00003	00003
00004	00004	00004
00005	00005	00005
00006	00006	00006
00007	00007	00007
00008	00008	00008
00009	00009	00009
00010	00010	00010
00011	00011	00011
00012	00012	00012
00013	00013	00013
00014	00014	00014
00015	00015	00015
00016	00016	00016
00017	00017	00017
00018	00018	00018
00019	00019	00019
00020	00020	00020
00021	00021	00021
00022	00022	00022
00023	00023	00023
00024	00024	00024
00025	00025	00025
00026	00026	00026
00027	00027	00027
00028	00028	00028
00029	00029	00029
00030	00030	00030
00031	00031	00031
00032	00032	00032
00033	00033	00033
00034	00034	00034
00035	00035	00035
00036	00036	00036
00037	00037	00037
00038	00038	00038
00039	00039	00039
00040	00040	00040
00041	00041	00041
00042	00042	00042
00043	00043	00043
00044	00044	00044
00045	00045	00045
00046	00046	00046
00047	00047	00047
00048	00048	00048
00049	00049	00049
00050	00050	00050
00051	00051	00051
00052	00052	00052
00053	00053	00053
00054	00054	00054
00055	00055	00055
00056	00056	00056
00057	00057	00057
00058	00058	00058
00059	00059	00059
00060	00060	00060
00061	00061	00061
00062	00062	00062
00063	00063	00063
00064	00064	00064
00065	00065	00065
00066	00066	00066
00067	00067	00067
00068	00068	00068
00069	00069	00069
00070	00070	00070
00071	00071	00071
00072	00072	00072
00073	00073	00073
00074	00074	00074
00075	00075	00075
00076	00076	00076
00077	00077	00077
00078	00078	00078
00079	00079	00079
00080	00080	00080
00081	00081	00081
00082	00082	00082
00083	00083	00083
00084	00084	00084
00085	00085	00085
00086	00086	00086
00087	00087	00087
00088	00088	00088
00089	00089	00089
00090	00090	00090
00091	00091	00091
00092	00092	00092
00093	00093	00093
00094	00094	00094
00095	00095	00095
00096	00096	00096
00097	00097	00097
00098	00098	00098
00099	00099	00099
00100	00100	00100

## Simple Spindle Phase Synchronization Function

The spindle phase synchronization for machining profile bars required complicated procedures with conventional models, but this procedure is partially automated by this function. Simple button operation following the instructions displayed on the screen enables smooth adjustment.

## Convenient maintenance timer & counter !

The number of maintenance timers is increased to 10 (Note\*) to enable character input to the reference column. Besides the maintenance timer, a maintenance counter is also added to control the time and count.

NO.	REFERENCE	UNIT
1	500H	0H
2	4000H	0H
3	30000H	0H
4	20000H	0H
5	10000H	0H
6	5000H	0H
7	1000H	0H
8	500H	0H
9	100H	0H
10	10H	0H

Note \*  
This number is 5 for SR-20RIV.

## Convenient Undo Function

In case of the wrong input, simply press the [Undo] key to revert back to the previous value. \*The undo function is usable on the wear offset screen and geometry offset screen.

## Convenient insulation deterioration detection function!

Insulation deterioration of servo motor, spindle motor and their power cables is automatically detected. Therefore, potential trouble can be located for maintenance and replacement of parts before the machine stops. In addition to insulation deterioration, a power fault, FSSB cable deterioration and various detector faults can also be detected.



## □ Standard Machine Specifications

OP : Option

Item		Specifications
Max. machining diameter		φ38mm(1-1/2in)
Max. headstock stroke	Standard	320mm(12-19/32in)
	With R,M,G,B. unit	288mm(11/32in) : OP
	Non-guide bush type	Bar diameter×2.5(Max.95mm)(Max.3-47/64in) : OP
Tool		5 tools on the front(stationary type)+2 tools on the rear(X3 axis control)
5-Spindle sleeve holder	Number of tools	Front 5 tools Rear 5 tools
	Max. drilling capability	φ23mm(29/32in)
	Max. tapping capability	M16×P2.0
Power driven attachment	Number of tools	Cross milling : 4 tools Cartridge type : At 2 position
	Number of tools	B-axis controlled power-driven tool unit : At 1 position (Front 3 tools+Rear 3 tools)
	Max. drilling capability	φ10mm(25/64in)
	Max. tapping capability	M8×P1.25
	Spindle speed	Max.6,000min <sup>-1</sup>
	Drive motor	2.2kW(continuous) / 3.0kW(5min./30%ED)
Rapid feed rate		36m/min(X1,Y1,Z1,X2,Z2), 24m/min(Y2,X3)
Main spindle indexing angle		C-axis control
Main spindle speed		Max.7,000min <sup>-1</sup>
Main spindle motor		7.5kW(continuous) / 11kW(10min./25%ED)
Coolant tank capability		253 ℓ (359 ℓ : OP)
Dimensions (W×D×H)		2,740×1,315×2,120mm
Weight		4,300kg
Power consumption		16.9 kVA

## □ Backworking Attachment Specifications

Item		Specifications	
Max. chucking diameter		φ38mm(1-1/2in)	
Max. length for front ejection		150mm(5-7/8in)	
Max. parts projection length		70mm(2-3/4in)	
Back 8-Spindle unit	Number of tools	8 tools	
	Max. drilling capability	Stationary tool	φ14mm(35/64in)
		Power driven tool	8 mm(5/16in)
	Max. tapping capability	Stationary tool	M12×P1.75
Power driven tool		M6×P1.0	
Power-driven att. spindle speed		Max.6,000min <sup>-1</sup>	
Power-driven att. drive motor		1.0kW(continuous) / 1.2kW(5min./30%ED)	
Sub spindle indexing angle		C-axis control	
Sub spindle speed		Max.7,000min <sup>-1</sup>	
Sub spindle motor		3.7kW(continuous) / 5.5kW(10min./40%ED)	

## □ External Dimensions

Unit : mm(ft)

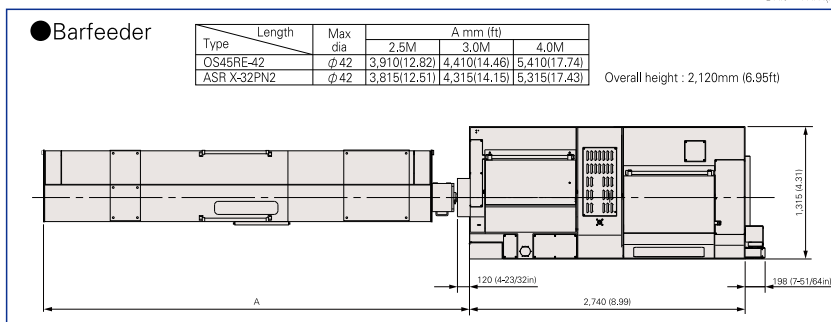

## □ Standard Accessories and Functions

1. CNC unit FANUC 31i-B5
2. Operation panel 10.4-inch color LCD display
3. Pneumatic unit
4. Hydraulic unit
5. Automatic centralized lubrication unit
6. Coolant level detector
7. Door interlock system
8. Broken cutoff tool detector
9. Drive unit for revolving guide bush
10. Revolving guide bush unit
11. Air purge unit for revolving guide bush
12. Main/Sub collet
13. C-axis control (Main/Sub)
14. Spindle clamp unit (main/sub)
15. 5-station tool holder □16/20mm
16. 2 tool holder □16mm
17. 5-spindle sleeve holder
18. Cross milling tool unit (4-tool type)
19. 3-spindle opposing unit with B axis control
20. Air purge unit for sub spindle
21. 8-spindle back working unit with Y axis control function
22. 8-spindle back working unit power tool drive
23. Parts conveyor
24. Work light
25. Leakage breaker

## □ Optional Accessories and Functions

1. Coolant flow detector
2. Parts ejection detector
3. Water removal unit
4. Beacon
5. Chip conveyor
6. Rotary magic guide bush unit
7. For pneumatic unit rotary magic guide bush
8. Main spindle inner tube
9. Non-guide bush type
10. Parts ejector (Air cylinder type)
11. Spacer set
12. Parts ejector (Spring type)
13. Parts ejector with guide tube
14. Parts stopper unit
15. Coolant unit (6.9MPa / 2.5MPa / 0.7MPa)
16. Coolant tank large capacity type
17. Coolant unit signal cable
18. Coolant unit power cable
19. Coolant valve (6.9MPa / 2.5MPa)
20. Coolant pipings
21. Automatic bar feeder interface
22. Compliant with the RS-232C interface
23. LAN interface
24. Transformer CE marking version
25. Transformer CE marking cable
26. CE marking version

(Note)

The machining capacities apply to SUS303 material. The machining capacities may differ from listed values depending on the machining conditions, such as the material to be machined or the tools to be used.

※Design features, specifications and technical execution are subject to change without prior notice.

※This product is an export control item subject to the foreign exchange and foreign trade laws. Thus, before exporting this product, or taking it overseas, contact your STAR MICRONICS dealer.

# STAR MICRONICS CO., LTD.

## Machine Tools Division

1500-34 Kitanoya, Misawa, Kikugawa, Shizuoka, 439-0023 Japan  
TEL,+81-537-36-5594 FAX,+81-537-36-5607

<https://star-m.jp/eng/>

**Star CNC Machine Tool Corporation**  
123 Powerhouse Road, Roslyn Heights, NY11577, U.S.A.  
TEL,+1-516-484-0500 FAX,+1-516-484-5820

**Star Micronics GB Limited**  
Unit 1 Riverlands Business Park Raynesway DERBY DE21 7BZ  
TEL,+44-1332-86-44-55 FAX,+44-1332-86-40-05

**Star Micronics GmbH**  
Robert-Grob-Str.1,D-75305 Neuenbürg,Germany  
TEL,+49-7082-7920-0 FAX,+49-7082-7920-20

**Star Micronics AG**  
Lauetstrasse3,CH-8112 Otelfingen,Switzerland  
TEL,+41-43-411-60-60 FAX,+41-43-411-60-66

**Star Machine Tool France**  
90 Allée de Glaisy,ZI,74300 Thyez Haute Savoie,France  
TEL,+33-450-96-05-97 FAX,+33-450-96-91-54

**Shanghai Xingang Machinery Co.,Ltd.**  
2F, 229 Fute Rd.N. The China (Shanghai) Pilot Free Trade Zone  
TEL,+86-21-5868-2100 FAX,+86-21-5868-2101

**Star Micronics (Thailand) Co.,Ltd.**  
289/23 M.13 Soi Kingkaew 25/1, Kingkaew Rd.,T.Rachathewa A.Bangplee Samutprakarn 10540,Thailand  
TEL,+66-2-186-8945-47 FAX,+66-2-183-7845

**9001 ISO 14001**  
CERTIFIED

2022.12\_Ver1.2\_4